

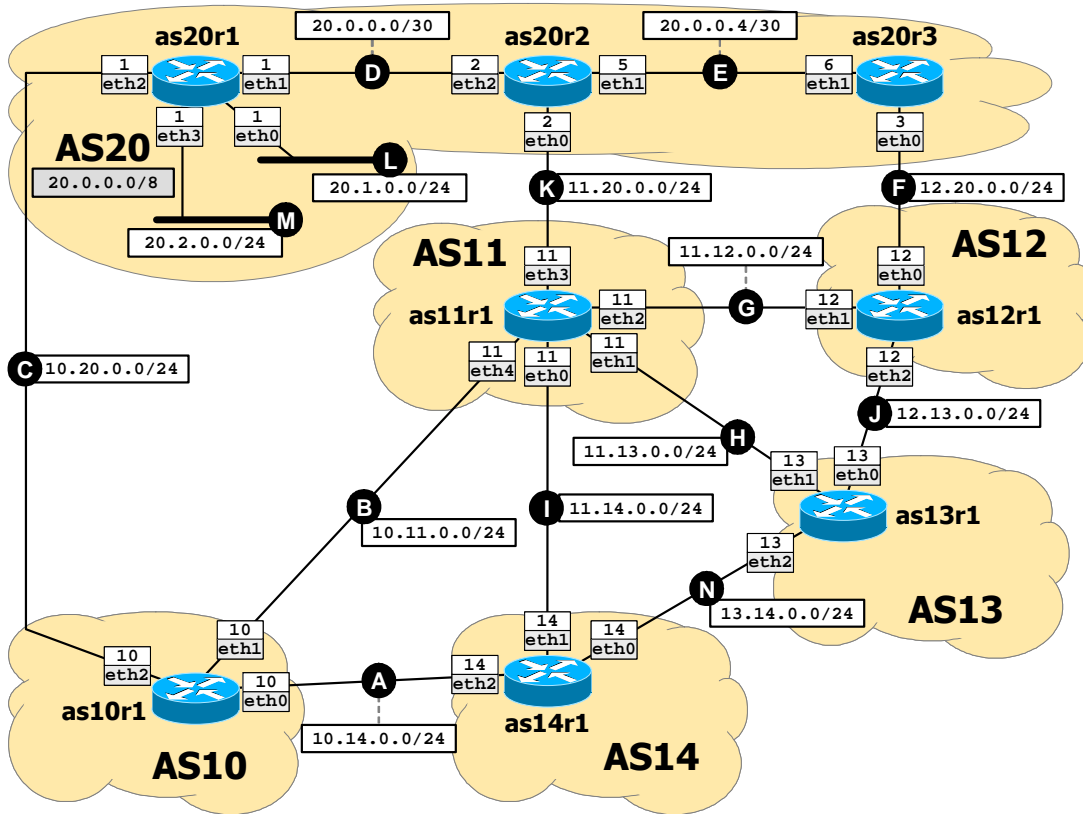

Available time: 120 minutes.



Using Netkit, implement the network shown in the figure and described below (you can use the following items as a checklist).

- Routers in AS20 use the RIP protocol.
- All peering LANs are announced in BGP.
- BGP routers in AS20 also announce the aggregate network 20.0.0.0/8.
- BGP routers in AS20 **do not** establish iBGP peerings.
- No routers announce 0.0.0.0/0 or apply customer-provider policies.
- as10r1 applies filters in such a way to **avoid** sending traffic to AS20 through link C.
- as10r1, as11r1, as12r1, as13r1, and as14r1 prefer sending traffic to 20.1.0.0/24 and 20.2.0.0/24 along the paths depicted in Figure 1.

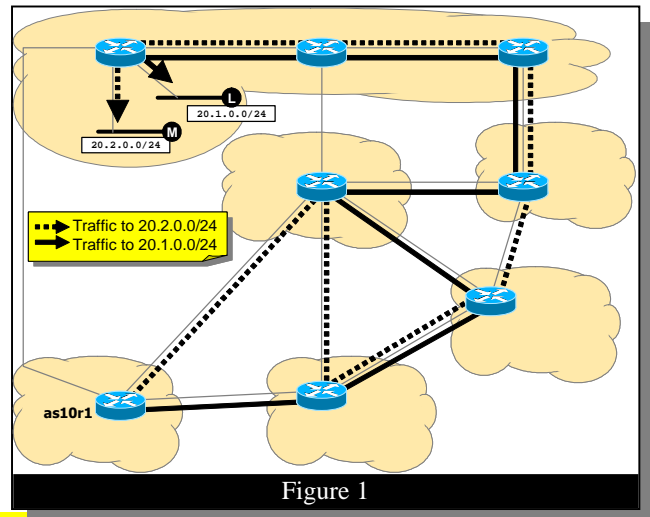

Figure 1

Goals:

- All routers must be able to reach any destinations.
- as10r1 must reach AS20’s networks L and M using the specified paths.



Available time: 120 minutes.

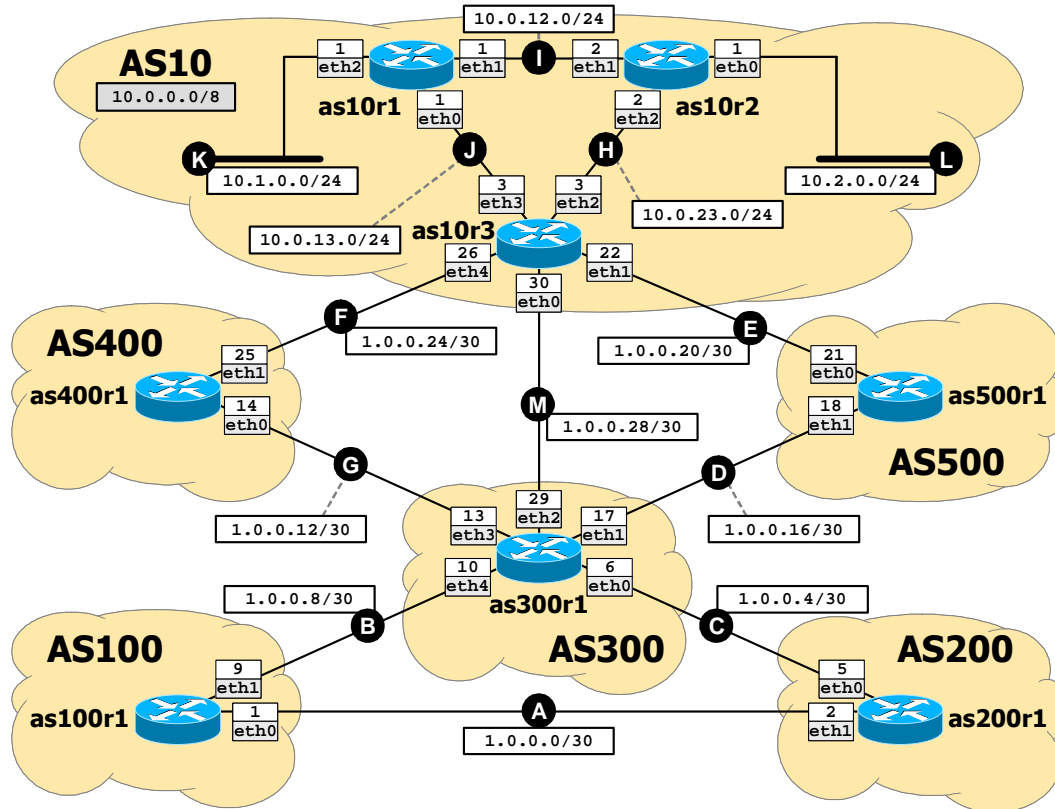

Using Netkit, implement the network shown in the figure and described below (you can use the following items as a checklist).

- Routers in AS10 use the RIP protocol.
- All peering LANs are announced in BGP.
- BGP routers in AS10 also announce the aggregate network 10.0.0.0/8.
- No routers announce 0.0.0.0/0 or apply customer-provider policies.
- as100r1 applies filters in such a way to **avoid** sending traffic to AS10 through link B.
- as200r1, as300r1, as400r1, and as500r1 **prefer** sending traffic to 10.1.0.0/24 and 10.2.0.0/24 along the paths depicted in Figure 1.

Goals:

- All routers must be able to reach any destinations.
- as100r1 must reach AS10’s networks K and L using the specified paths.

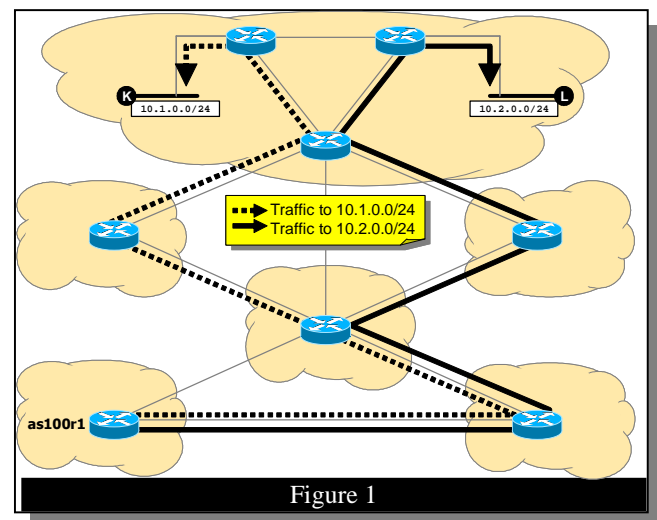
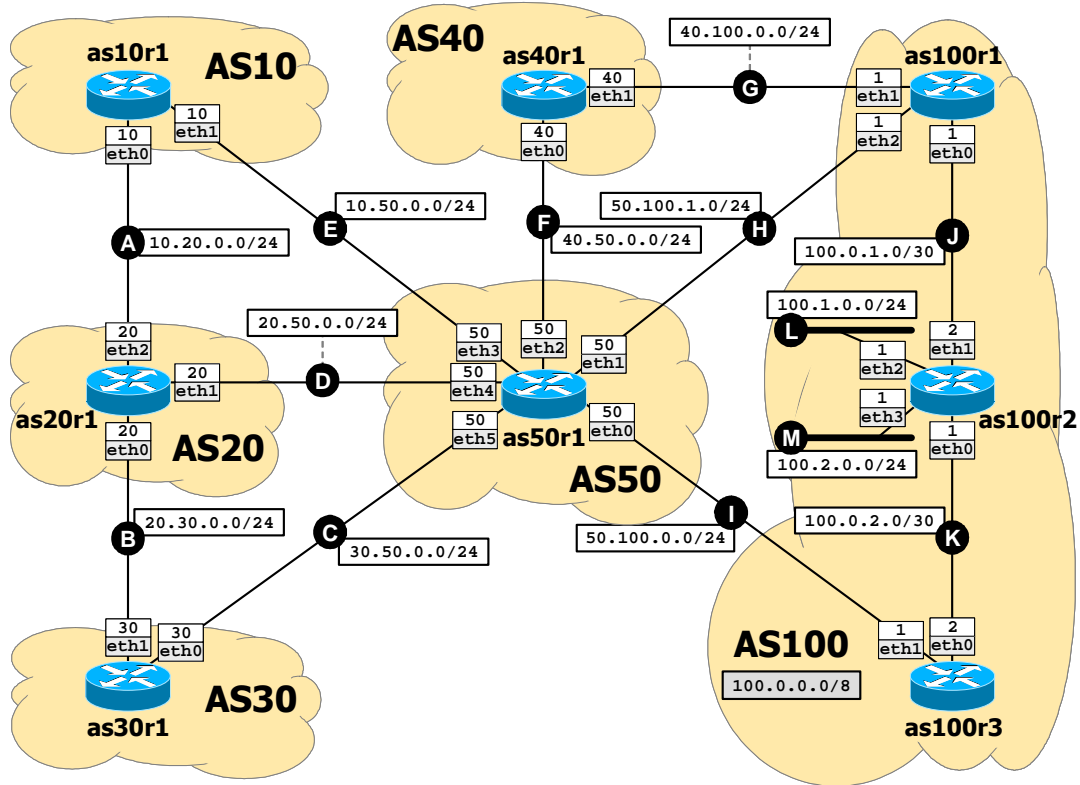

Figure 1



Available time: 120 minutes.



Using Netkit, implement the network shown in the figure and described below (you can use the following items as a checklist).

- Routers in AS100 use the RIP protocol.
- All peering LANs are announced in BGP.
- BGP routers in AS100 also announce the aggregate network 100.0.0.0/8.
- BGP routers in AS100 **do not** establish iBGP peerings.
- No routers announce 0.0.0.0/0 or apply customer-provider policies.
- as50r1 applies filters in such a way to **avoid** sending traffic to AS100 through links H and I.
- as10r1, as20r1, as30r1, and as40r1 prefer sending traffic to 100.1.0.0/24 and 100.2.0.0/24 along the paths depicted in Figure 1.

Goals:

- All routers must be able to reach any destinations.
- as10r1 must reach AS100’s networks L and M using the specified paths.

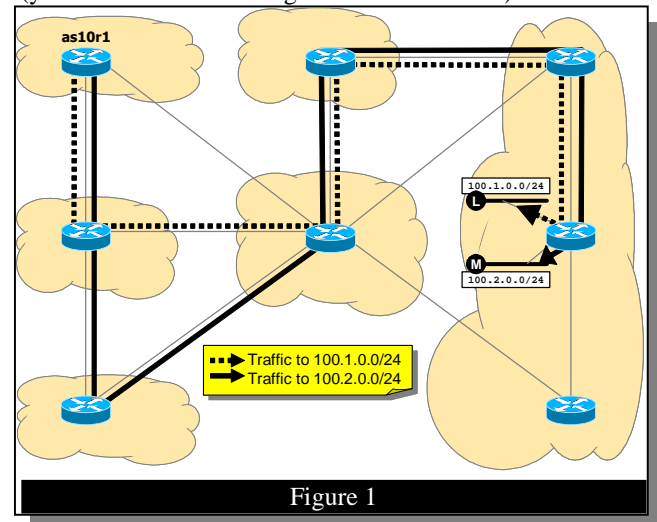

Figure 1



Available time: 120 minutes.

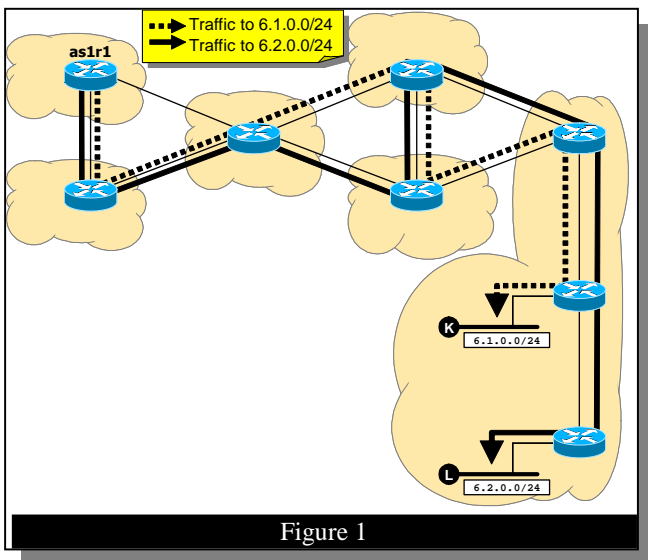
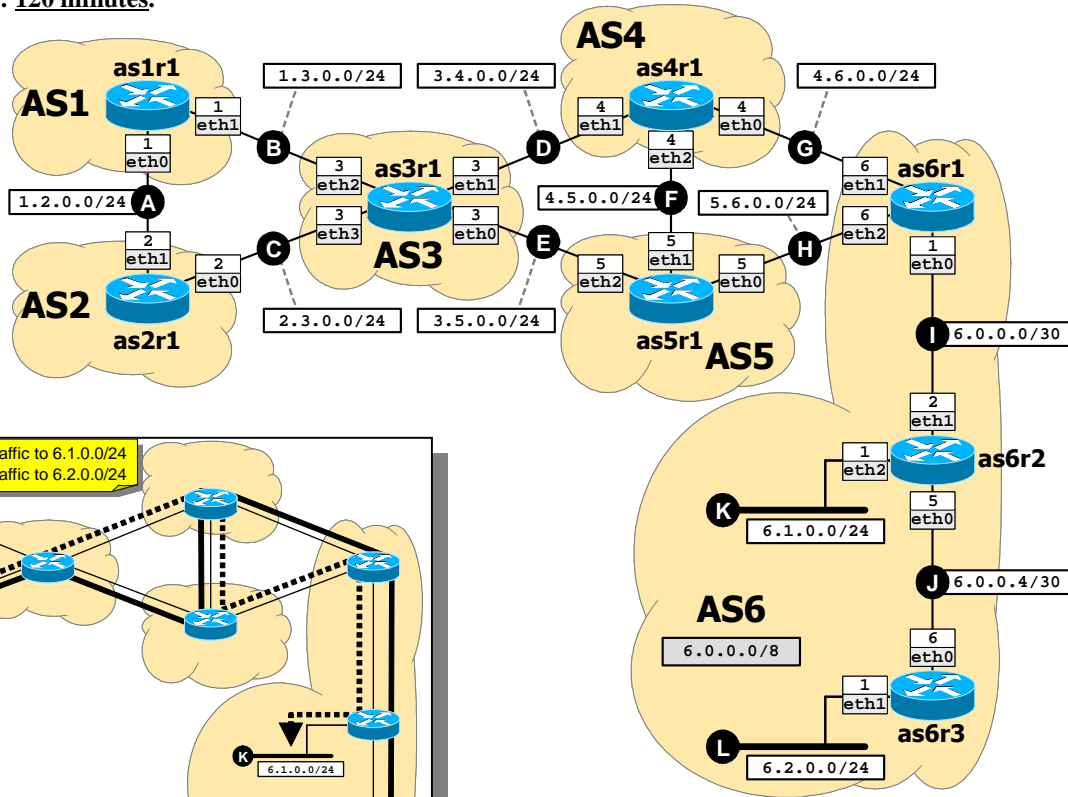

Figure 1

Using Netkit, implement the network shown in the figure and described below (you can use the following items as a checklist).

- Routers in AS6 use the RIP protocol.
- All peering LANs are announced in BGP.
- BGP routers in AS6 also announce the aggregate network 6.0.0.0/8.
- No routers announce 0.0.0.0/0 or apply customer-provider policies.
- as1r1 applies filters in such a way to **avoid** sending traffic to AS6 through link B.
- as2r1, as3r1, as4r1, and as5r1 prefer sending traffic to 6.1.0.0/24 and 6.2.0.0/24 along the paths depicted in Figure 1.

Goals:

- All routers must be able to reach any destinations.
- as1r1 must reach AS6's networks K and L using the specified paths.