

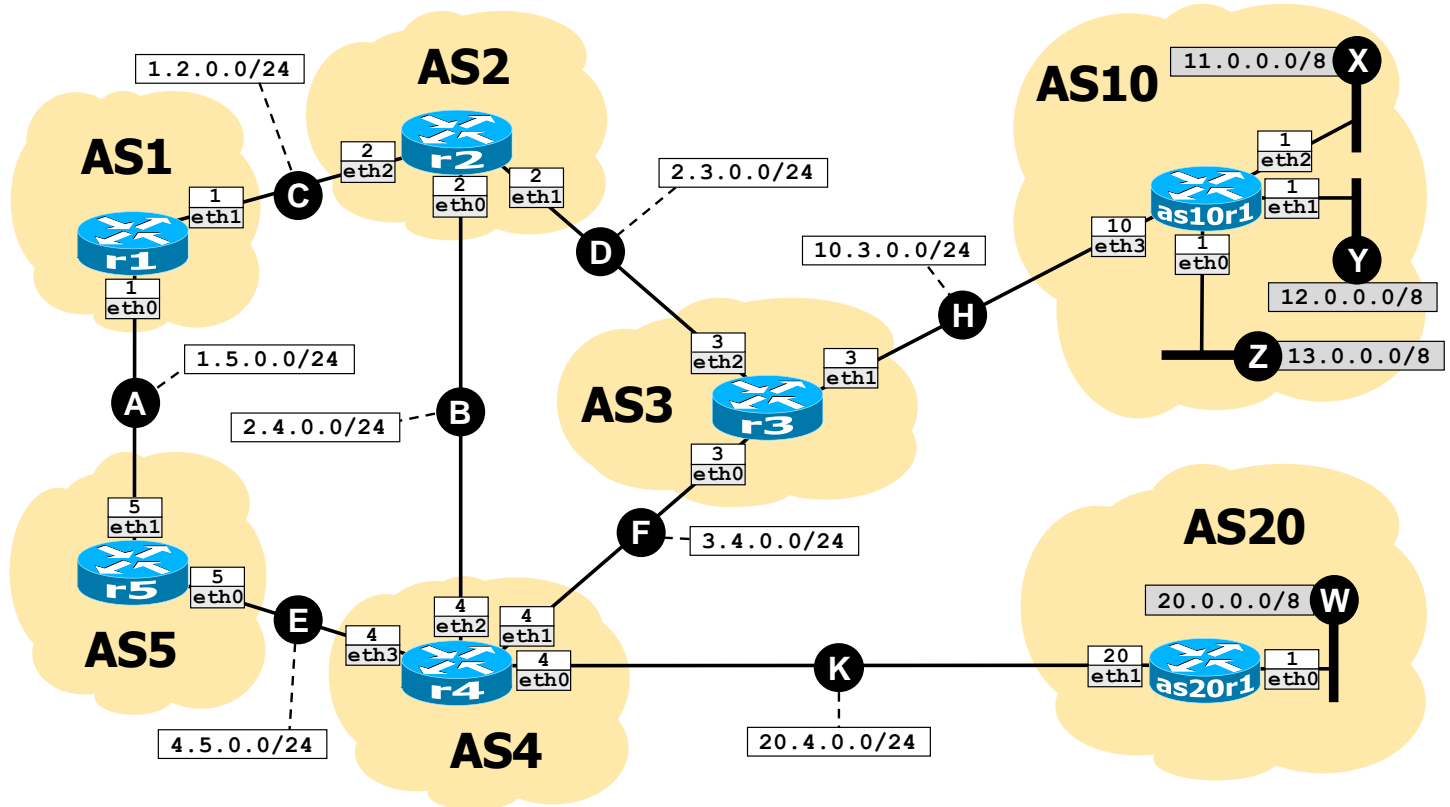

Available time: 90 minutes.



Using Netkit, implement the network depicted in the figure above and described below.

- All peering LANs are announced in BGP. No routers announce the default route 0.0.0.0/0.
- as10r1 and as20r1 also announce in BGP their own internal subnets, in gray color. In particular, as10r1 behaves as follows:
 - it announces network 11.0.0.0/8 normally;
 - it tags announcements of network 12.0.0.0/8 using community 10:1;
 - it tags announcements of network 13.0.0.0/8 using community 10:2.
- BGP routers within AS1, AS2, AS3, AS4, and AS5 are set up to deal with BGP announcements originated by AS10 depending on the communities they carry, with the following criteria:
 - announcements tagged with community 10:1 must be propagated exclusively along path H-D-C-A-E-K;
 - r4 prefers announcements tagged with community 10:2 received through link B.

HOW TO SET A BGP COMMUNITY
Inside a route-map: set community <i>communityValue</i>
HOW TO MATCH A BGP COMMUNITY
ip community-list standard <i>c1Name</i> permit <i>communityValue</i> Then, inside a route-map: match community <i>c1Name</i>

Goal: All the BGP peerings must operate correctly. All router pairs must be mutually reachable. Routing from AS20 to AS10 must be consistent with the requested BGP policies (check it using traceroute).



Available time: 90 minutes.

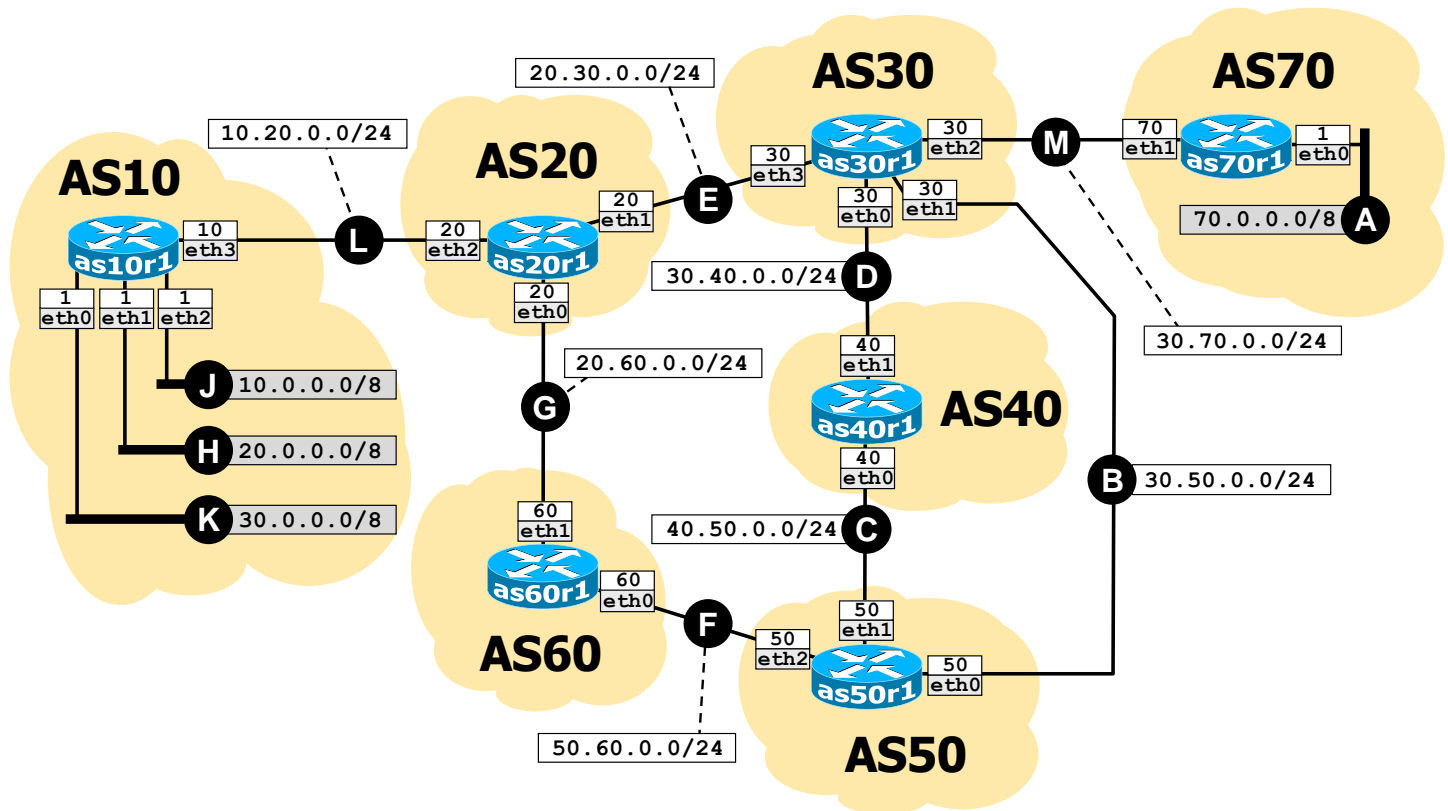

Using Netkit, implement the network depicted in the figure above and described below.

- All peering LANs are announced in BGP. No routers announce the default route 0.0.0.0/0.
- as10r1 and as70r1 also announce in BGP their own internal subnets, in gray color. In particular, as10r1 behaves as follows:
 - it announces network 10.0.0.0/8 normally;
 - it tags announcements of network 20.0.0.0/8 using community 10:1;
 - it tags announcements of network 30.0.0.0/8 using community 10:2.
- BGP routers within AS20, AS30, AS40, AS50, and AS60 are set up to deal with BGP announcements originated by AS10 depending on the communities they carry, with the following criteria:
 - announcements tagged with community 10:1 must be propagated exclusively along path L-G-F-C-D-M;
 - as50r1 prefers announcements received from AS60;
 - as30r1 prefers announcements tagged with community 10:2 received through link B.

```

HOW TO SET A BGP COMMUNITY
Inside a route-map:
    set community communityValue

HOW TO MATCH A BGP COMMUNITY
ip community-list standard c1Name permit
communityValue
Then, inside a route-map:
    match community c1Name
    
```

Goal: All the BGP peerings must operate correctly. All router pairs must be mutually reachable. Routing from AS70 to AS10 must be consistent with the requested BGP policies (check it using traceroute).